

GAS FIREPLACES



INDEX

G A S F I R E P L A C E S

About us

2

Why Planika?

5

Flue systems

6

Safety

7

Technology

9

Custom options

11

Sinatra

13

Versal

21

Valentino

29

Monroe

35

Galio

41

Galio FirePit

47

Product Comparison

50

Technical drawings

52

ABOUT US

Planika would like to introduce you to the amazing world of modern gas fireplaces. We join the warmth of natural fire with the advanced and safe technology that Planika offers, creating unique and highly functional fire solutions. It allows us to achieve the effect of dancing flames in their natural golden colour. With wide expertise in designing and developing advanced fireplaces, Planika gained recognition all around the world.

Today, Planika is selling products in more than 80 countries, achieving more and more appreciation among architects and clients of the private and commercial sector. The fireplaces are designed and developed by a professional group of engineers at Planika's laboratory, equipped with the most advanced measuring and testing instruments. Each product is carefully tested prior to selling it, ensuring the best quality and safety of Planika's fireplaces.

We do believe that Planika's success lies in our approach to fire design that is based on a constantly changing technology and solutions. It allows us to create truly advanced fireplaces. Extensive technical knowledge and experience taught us to design every product from start to finish. By selecting the highest quality materials, components and technological solutions, Planika has come up with fireplaces that meet the most restrictive requirements of architects and designers. To provide the finest and reliable products, our specialists constantly keep updating and modernizing the implemented technologies.

Due to this innovative approach to the needs of our customers, Planika has become the world leader in designing, manufacturing and distributing advanced automatic gas and bioethanol fireplaces for both commercial and residential spaces.

Trust our technology and find out for yourself!









WHY PLANIKA?

WHY TO CHOOSE US?

WORLDWIDE EXPERIENCE

- Over 15 years on the international market
- Leadership in the fireplace industry
- Numerous projects on every continent
- Appreciation in over 80 countries
- Top private and commercial projects (Marriott, Hilton, Kempinski and many more)

ENVIRONMENT FRIENDLY

- No harmful by-products
- No smell, smoke and ash
- Energy efficient
- Consistent heat supply
- Closed or open combustion system

CUSTOMIZATION

- Custom length and configuration
- Versatile installation options
- Designed to fit in any interior conception
- LPG or natural gas supplied
- Different finish and glazing options
- Help from the Projects Department

ADVANCED SAFETY FEATURES

- Multiple safety sensors: gas, CO and seismic activity
- Child lock
- Advanced thermostat for constant heat
- Service reminder
- Automatic ignition
- Certified solutions
- Draft interrupter

CONVENIENCE OF USE

- Smart Home System compatible
- Remote control
- Mobile device control (mobile application via Wi-Fi)
- 15 levels of flame height
- Eco flow mode
- Modular structure
- MI System (Modular Ignition System)

UNIQUE DESIGN

- Anti-reflective glass
- Linear-shape/campfire /fire pit burners
- Adjustable frame
- Authentic-looking decorative logs and accessories
- LED / ambient lighting
- Warm, glowing flames

FLUE SYSTEMS

BALANCED FLUE SYSTEM

VALENTINO & MONROE

provides a hermetically sealed burning process which does not affect the air in the room. The concentric structure (Ø200 mm/130 mm) allows for extraction of any combustion products outside the building (inner pipe Ø130 mm) and supplying fresh air for the burning process (outer pipe Ø200 mm) at the same time.

CONVENTIONAL FLUE SYSTEM

SINATRA & VERSAL

relies on the natural circulation of heated air to extract the combustion byproducts through the chimney. Air for the combustion is supplied from the room where the gas fire or stove is installed in (it is not supplied through the flue).

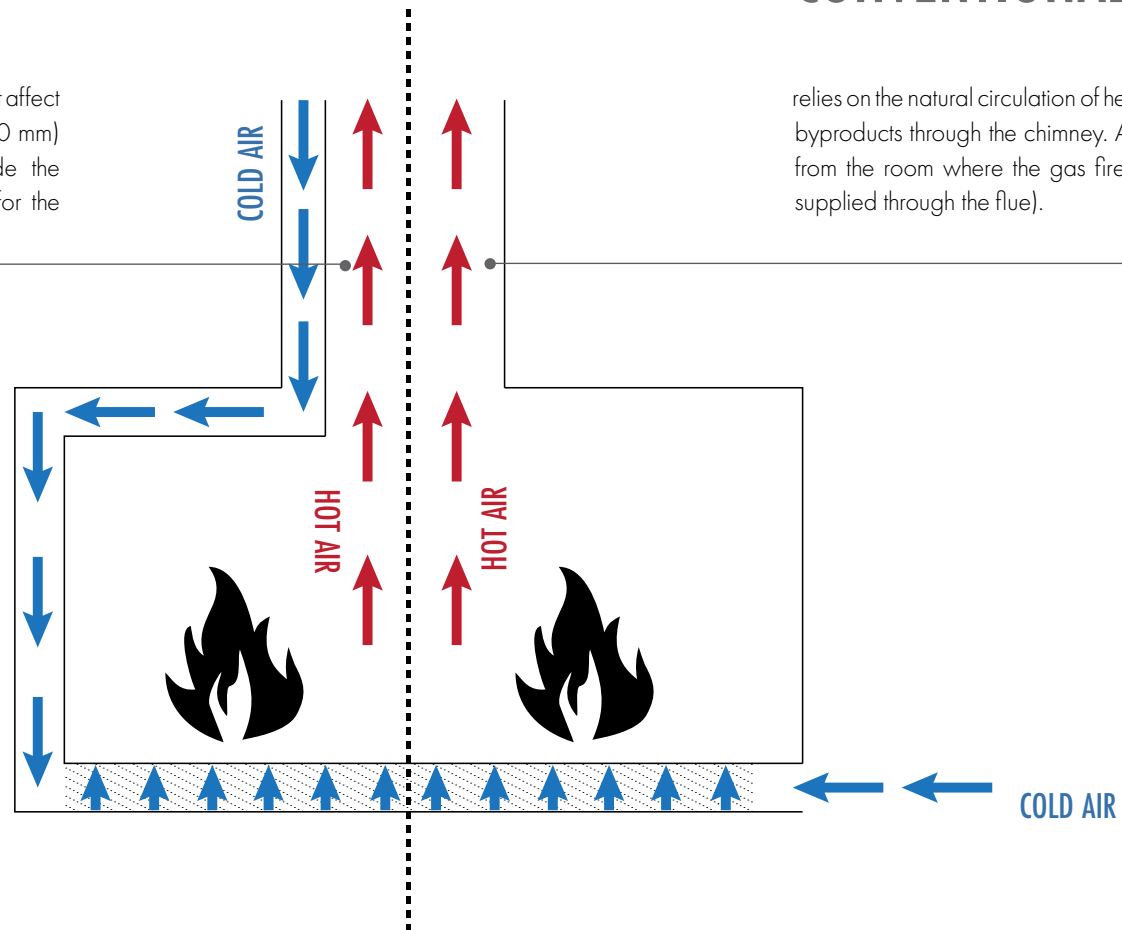

SAFETY

BURNING CONTROL SYSTEM



The advanced electronic components combined with multiple safety sensors, monitor the operation of the fireplace and turn the device off in case any disfunction is detected.

- a) CO sensor - an advanced safety feature aiming to detect any leaks in the flue system.
- b) Gas sensor - in case any gas leaks are detected, the main valve is closed, turning the fireplace off immediately.
- c) Seismic activity sensor - to ensure the highest level of safety, the fireplace is automatically deactivated if any shakes are detected.
- d) Draft interrupter - turns off the fireplace automatically in case the airflow is reversed.

FLAME CONTROL



An ionizing electrode controls the flame - should it unexpectedly go out, the gas supply will be automatically disconnected.

CHILD LOCK



In order to be turned on, the device requires a fixed sequence of buttons to be pushed. This feature minimizes the risk of unwanted activation of the fireplace.

CERTIFIED CONSTRUCTION



Planika's products and components have successfully passed extensive tests carried out by the leading certification institutes meeting the most demanding European safety and quality requirements.

SERVICE REMINDER



Once a year, the fireplace automatically informs the user about the scheduled service. The reminder helps to maintain proper device operation at all times.





Sintra Island 2000

TECHNOLOGY

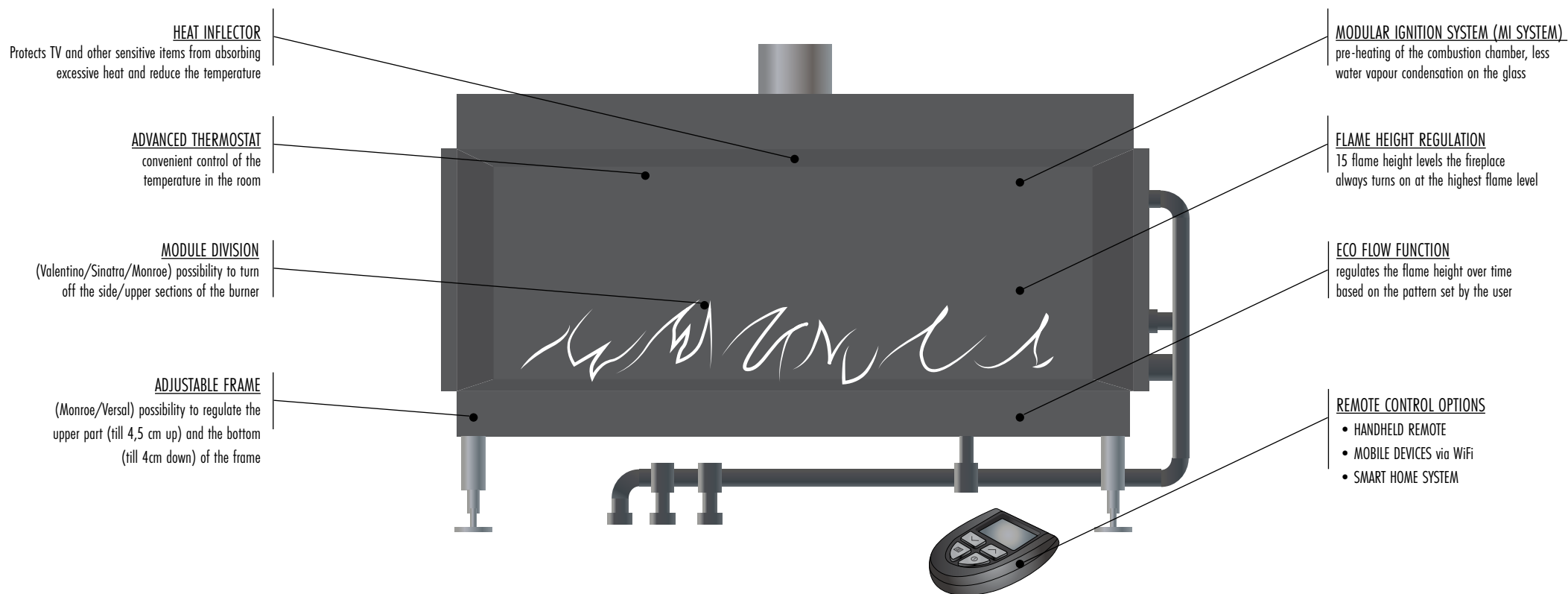



Sinatra Tunnel 2000

CUSTOM OPTIONS

SOLUTIONS WE OFFER

FLUE TYPE

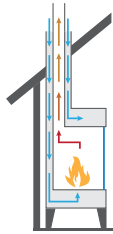

BALANCED FLUE SYSTEM
(VALENTINO & MONROE)

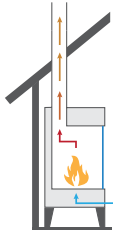

CONVENTIONAL FLUE SYSTEM
(SINATRA & VERSAL)

FUEL TYPE



NATURAL GAS



LPG GAS

GLAZING OPTIONS



FRONT



DOUBLE SIDED
(CORNER)



THREE SIDED



ROOM DIVIDER



ISLAND



TUNNEL

OTHER CUSTOM OPTIONS



CUSTOM LENGTH
(800-2400 MM PER ONE UNIT)



CUSTOM SHAPES



GLAZING/NO GLAZING
GLASS HEIGHT 400 - 1200 MM

SINATRA

THE POWER OF CUSTOM



SINATRA

CUSTOM / CONVENTIONAL FLUE SYSTEM

FEATURES

Linear-shape burner
15 levels of flame height
LPG or Natural Gas powered
CO sensor

Gas sensor
Child lock
Eco flow mode
Module division mode

Remote control
Smart Home System compatible
Automatic ignition
CE Certified

Ceramic or anti-reflective glass
No glazing option
Bespoke sizes
MI System

TECHNICAL DATA

Front glass length [mm]	1200		1600		2000		2400	
Fuel option	NG (G20/G25)	LPG (G30/G31)	NG (G20/G25)	LPG (G30/G31)	NG (G20/G25)	LPG (G30/G31)	NG (G20/G25)	LPG (G30/G31)
Nominal Heat Input (Hi) [kW]	10,31	9,51	14,95	14,26	19,74	19,01	19,75	19,96
Gas consumption [m ³ /h]	max. 1,09	-	max. 1,58	-	max. 2,09	-	max. 2,09	-
Gas consumption [kg/h]	-	max. 0,75	-	max. 1,12	-	max. 1,50	-	max. 1,57
Interior	Matt black painted steel / optional rear lining: black ceramic glass (high gloss)							
Flue system	Conventional flue							

GLAZING OPTIONS



FRONT (F)



LEFT-FRONT / FRONT-RIGHT (LF/FR)



LEFT-FRONT-RIGHT (LFR)



ROOM DIVIDER



TUNNEL



ISLAND



Sinatra Island 1600



Sinatra FR 800



Sinatra Tunnel 1200

SINATRA

F / LF / FR / LFR / ISLAND / TUNNEL / ROOM DIVIDER

1200, 1600, 2000, 2400, CUSTOM

CHIMNEY

Custom length and colour

OPTIONAL ACCESSORIES



- Decorative black diamond stones
- White pebbles
- Black glass embers



- LED lighting + crystal diamond embers
- LED lighting + crystal diamond embers + ceramic logs
- Vermiculite + ceramic logs

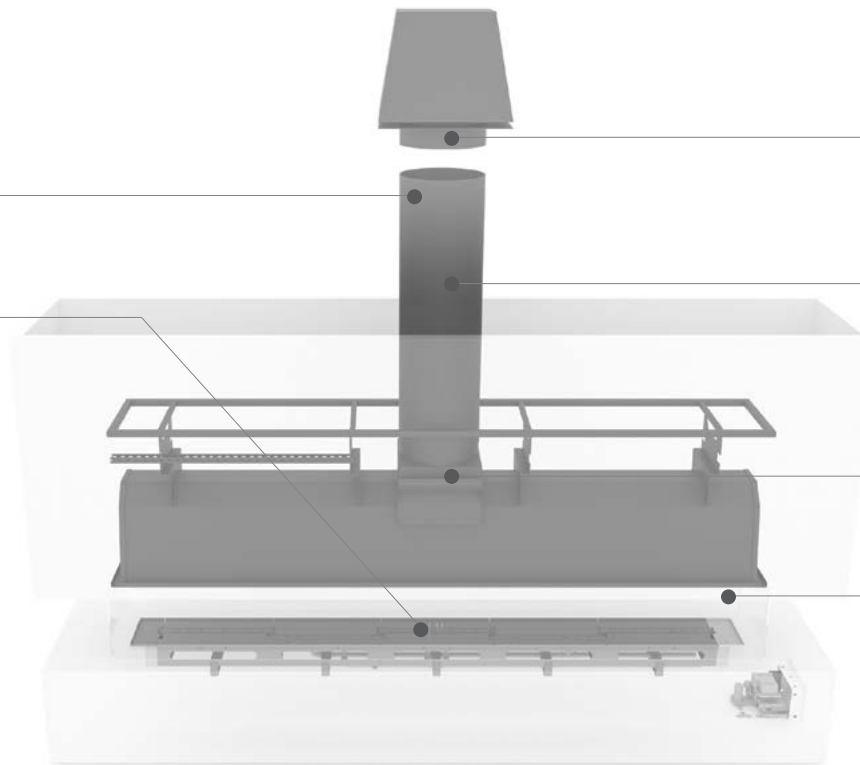

OPTIONAL FAN

Ø 200 or 300 mm

CONVENTIONAL FLUE

DRAFT INTERRUPTOR

CERAMIC OR ANTI-REFLECTIVE GLASS

No glazing option
Standard height 400 mm
Custom height 400-1200 mm



Sinatra LFR 600



Sintra LFR 1600

VERSAL

ECO ALTERNATIVE



Versal Cassette 600

VERSAL

STANDARD / CONVENTIONAL FLUE SYSTEM

FEATURES

15 levels of flame height
LPG or Natural Gas powered
CO sensor
Gas sensor

Convectional fan
Ambient lighting
Easy installation to existing chimneys
Child lock

Eco flow mode
Remote control
Smart Home System compatible
Automatic ignition

CE Certified
Ceramic glass

TECHNICAL DATA

Length [mm]	400		600		750		900	
Fuel option	NG (G20/G25)	LPG (G30/G31)	NG (G20/G25)	LPG (G30/G31)	NG (G20/G25)	LPG (G30/G31)	NG (G20/G25)	LPG (G30/G31)
Nominal Heat Input (Hi) [kW]	3,0	3,8	4,6	4,9	5,3	6,0	7,5	7,6
Gas consumption [m ³ /h]	max. 0,32	-	max. 0,49	-	max. 0,56	-	max. 0,79	-
Gas consumption [kg/h]	-	max. 0,3	-	max. 0,39	-	max. 0,47	-	max. 0,6
Interior	Matt black painted steel / optional lining: black ceramic glass (high gloss) or brick panel							
Flue system	Convectional flue							

OPTIONS





Versal Freestanding with Woodbox 400



Versal Cassette 600



Versal Cassette 750



Versal Freestanding with Woodbox 400



Versal Cassette 600 with Frame





Versal Cassette 600

VALENTINO

LONG LINE OF REAL FIRE



VALENTINO

STANDARD / BALANCED FLUE SYSTEM

FEATURES

Linear-shape burner
Anti-reflective glass
LPG / Natural Gas powered
CO sensor
Gas sensor

Seismic activity sensor
Child lock
Advanced thermostat
Service reminder
Remote control

Smart Home System compatible
Wi-Fi (mobile device control)
15 levels of flame height
Eco flow mode

Modular burner
Natural-looking accessories
Heat inflector
MI System

TECHNICAL DATA

Front glass length [mm]	1000		1300	
	Natural gas (G20/G25)	LPG (G30/G31)	Natural gas (G20/G25)	LPG (G30/G31)
Nominal Heat Output [kW]	6,4	6,7	8,5	7,4
Nominal Heat Input (Hi) [kW]	8,5	8,9	11,3	9,9
Gas consumption [m³/h]	0,25-0,9	-	0,29-1,2	-
Gas consumption [kg/h]	-	0,2-0,7	-	0,2-0,78
Interior	Matt black painted steel / optional rear lining: black ceramic glass (high gloss)			
Flue system [mm]	Concentric flue 200/130			

GLAZING OPTIONS



FRONT (F)



LEFT-FRONT (LF)



FRONT-RIGHT (FR)



LEFT-FRONT-RIGHT (LFR)



Valentino F 1300



Valentino LFR 1300



Valentino F 1000



Valentino FR 1300

MONROE

CAMPFIRE BURNER



MONROE

STANDARD / BALANCED FLUE SYSTEM

FEATURES

Campfire burner
Anti-reflective glass
LPG / Natural Gas powered
CO sensor
Gas sensor

Seismic activity sensor
Child lock
Advanced thermostat
Service reminder
Remote control

Smart Home System compatible
Wi-Fi (mobile device control)
15 levels of flame height
Eco flow mode

Modular burner
Natural-looking accessories
Heat inflector
MI System

TECHNICAL DATA

Front glass length [mm]	900	
Fuel option	Natural gas (G20/G25)	LPG (G30/G31)
Nominal Heat Output [kW]	8,3	9,2
Nominal Heat Input (Hi) [kW]	11,0	12,2
Gas consumption [m ³ /h]	0,22-1,2	-
Gas consumption [kg/h]	-	0,20-0,96
Interior	Matt black painted steel / optional rear lining: black ceramic glass (high gloss) or brick panel	
Flue system [mm]	Concentric flue 200/130	

GLAZING OPTIONS



FRONT (F)



LEFT-FRONT (LF)



FRONT-RIGHT (FR)



LEFT-FRONT-RIGHT (LFR)



Monroe F 900



Monroe F 900



Monroe LFR 900



Monroe LF 900

MONROE

FINISHING OPTIONS

VALENTINO

FINISHING OPTIONS

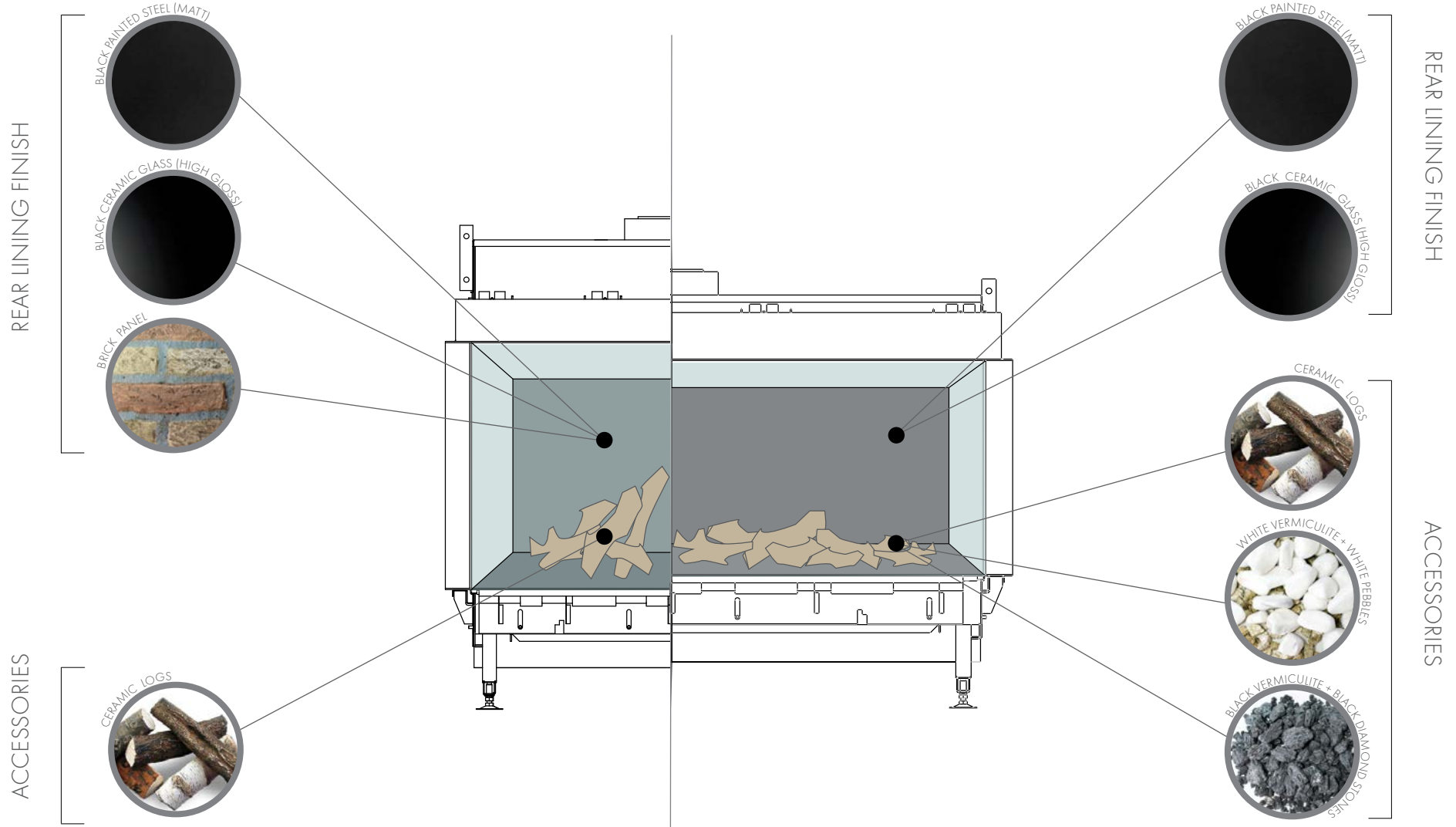

GALIO

OUTDOOR LINE OF FIRE



Galio Insert (Custom)

GALIO

CUSTOM AND STANDARD

FEATURES

For outdoor use	LPG/NG powered	Possibility of joining modules	Wi-Fi (mobile device control)
Easy installation	No electrical connection required	Easy start button	Remotely controlled
Flame height regulation	CE certified	Smart Home System compatible	
Linear-shape burner	Bespoke sizes		

TECHNICAL DATA

Fuel option	Galio Insert		Galio Corten	
	Natural gas (G20/G25)	LPG (G30/G31)	Natural gas (G20/G25)	LPG (G30/G31)
Nominal Heat Input (Hi) [kW]	4,7-9,4	6,3-11,8	4,7-9,4	6,3-11,8
Gas consumption [m ³ /h]	0,5-1	-	0,5-1	-
Gas consumption [kg/h]	-	0,5-0,93	-	0,5-0,93
Gas pressure [mbar]	20	37	20	37
Interior	stainless steel		CASING: corten steel + tempered glass BURNER: stainless steel	
Dimensions	1027 mm x 230 mm x 260 mm		1140 mm x 350 mm x 500 mm	

OPTIONS



GALIO CORTEN



GALIO INSERT



Galio Insert (Custom)





Galio Insert (Custom)



Galio Corten (Standard)



Galio Corten (Standard)

GALIO

OUTDOOR FIRE PIT



Galio Fire Pit Insert (Custom)



GALIO FIRE PIT

C U S T O M A N D S T A N D A R D

FEATURES

For outdoor use
Easy installation
Flame height regulation
Round-shape burner

LPG/NG powered
Safety sensor
No electrical connection required
CE certified

Bespoke sizes
Easy start button
Smart Home System compatible

Wi-Fi (mobile device control)
Remotely controlled

TECHNICAL DATA

Fuel option	Galio Fire Pit Insert		Galio Fire Pit Corten	
	Natural gas (G20/G25)	LPG (G30/G31)	Natural gas (G20/G25)	LPG (G30/G31)
Nominal Heat Input (Hi) [kW]	2,4-4,7	2,5-5,1	2,4-4,7	2,5-5,1
Gas consumption [m ³ /h]	0,25-0,5	-	0,25-0,5	-
Gas consumption [kg/h]	-	0,2-0,4	-	0,2-0,4
Gas pressure [mbar]	20	37	20	37
Interior	stainless steel		CASING: corten steel BURNER: stainless steel	
Dimensions	450 mm x 246 mm		950 mm x 350 mm	

OPTIONS



GALIO FIRE PIT CORTEN



GALIO FIRE PIT INSERT



Galio Fire Pit Insert (Custom)



Galio Fire Pit Corten (Standard)

PRODUCT COMPARISON

ADDITIONAL OPTIONS AND FUNCTIONS

	VALENTINO	MONROE	VERSAL	SINATRA
FLUE SYSTEM	BALANCED 200/130	BALANCED 200/130	CONVENTIONAL	CONVENTIONAL
ANTI-REFLECTIVE GLAZING	STANDARD	STANDARD	-	OPTIONAL
NO GLASS ENCLOSURE	-	-	-	STANDARD
BLACK CERAMIC GLASS (REAR LINING)	OPTIONAL	OPTIONAL	OPTIONAL	OPTIONAL
BRICK PANEL (REAR LINING)	-	OPTIONAL	OPTIONAL	OPTIONAL
LED LIGHTING	-	-	-	OPTIONAL
AMBIENT LIGHTING	-	-	STANDARD	-
CERAMIC LOGS + VERMICULITE	STANDARD	STANDARD	STANDARD	OPTIONAL
CRYSTAL DIAMOND EMBERS	-	-	-	OPTIONAL
BLACK DIAMOND STONES	STANDARD	-	-	OPTIONAL
WHITE PEBBLES	STANDARD	-	-	OPTIONAL
BLACK GLASS EMBERS	-	-	-	OPTIONAL
CHILD LOCK	STANDARD	STANDARD	STANDARD	STANDARD
ECO FLOW MODE	STANDARD	STANDARD	STANDARD	STANDARD

PRODUCT COMPARISON

ADDITIONAL OPTIONS AND FUNCTIONS

	VALENTINO	MONROE	VERSAL	SINATRA
THERMOSTAT	STANDARD	STANDARD	-	-
SMART HOME SYSTEM COMPATIBILITY	STANDARD	STANDARD	STANDARD	STANDARD
REMOTE CONTROL	STANDARD	STANDARD	STANDARD	STANDARD
WI-FI AND SERVICE REMINDER	OPTIONAL	OPTIONAL	OPTIONAL	OPTIONAL
CO SENSOR	STANDARD	STANDARD	STANDARD	STANDARD
GAS SENSOR	STANDARD	STANDARD	STANDARD	STANDARD
SEISMIC ACTIVITY SENSOR	STANDARD	STANDARD	-	-
BURNER	1 CENTRAL & 2 SIDE BURNERS	1 UPPER & 1 LOWER	1 CENTRAL	MUTIPLE, DEPENDING ON LENGTH
WALL BRACKET	-	-	OPTIONAL	-
WOODBBOX	-	-	OPTIONAL	-
GASBOX	-	-	OPTIONAL	-
HEAT INFLECTOR	STANDARD	STANDARD	-	-
CUSTOMIZATION	-	-	-	AVAILABLE
CONVECTIONAL FAN	-	-	STANDARD	-

VALENTINO

TECHNICAL DRAWINGS

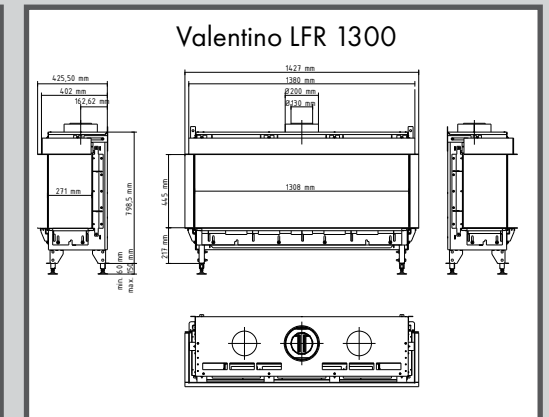
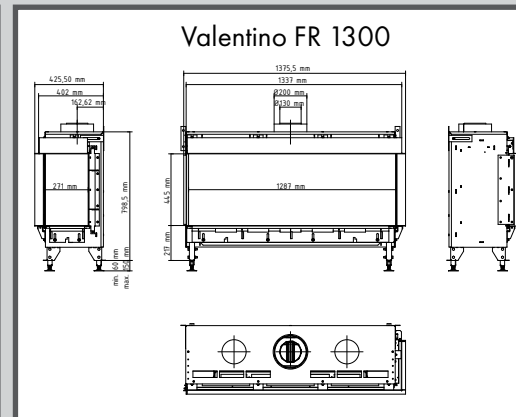
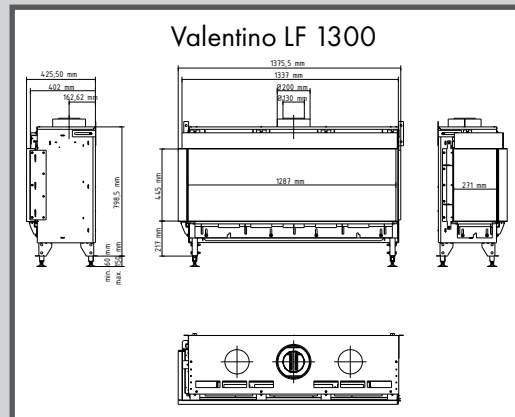
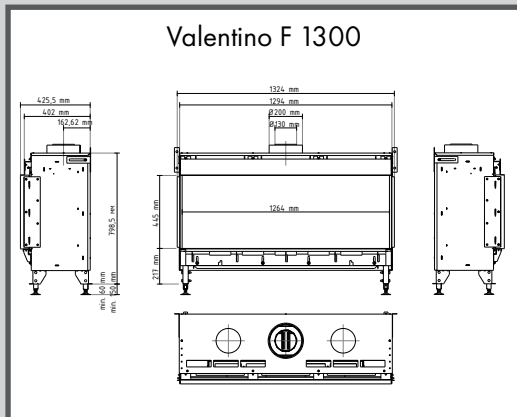
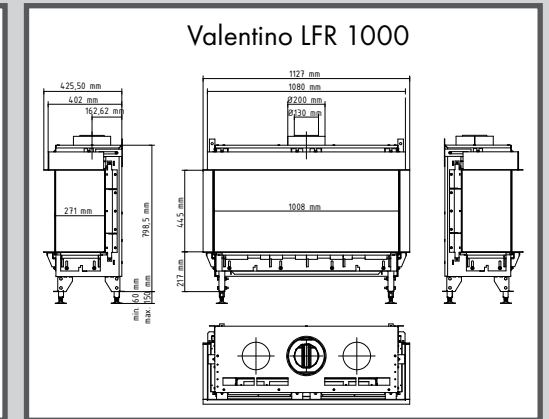
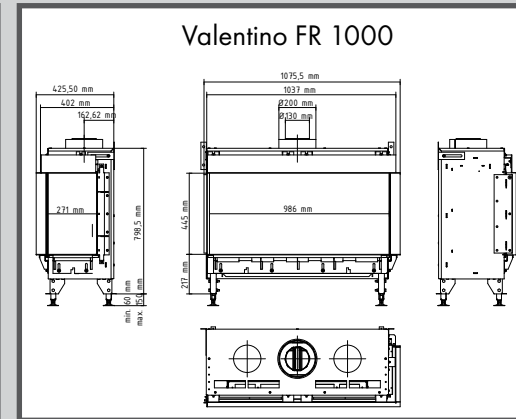
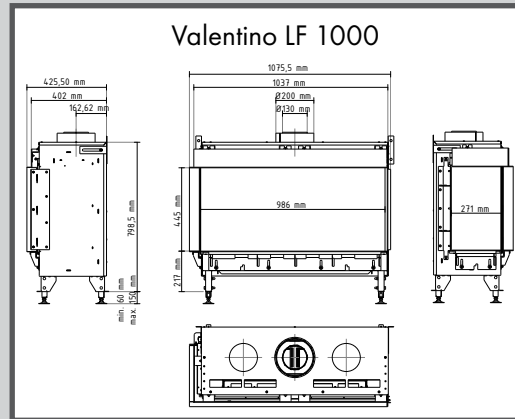
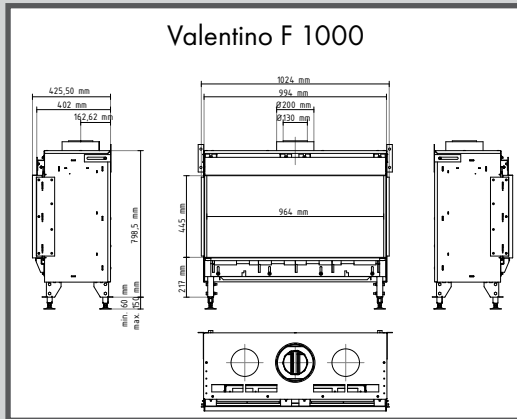

MONROE

TECHNICAL DRAWINGS

VERSAL INSERT

TECHNICAL DRAWINGS

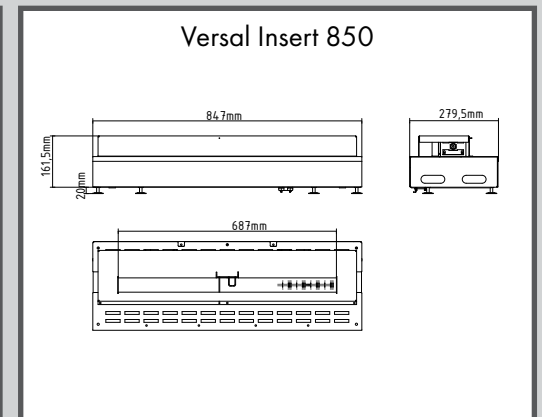
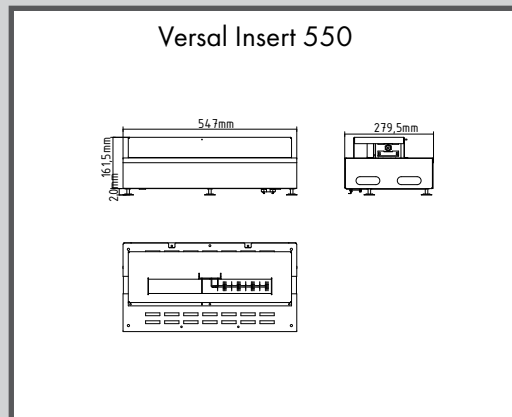
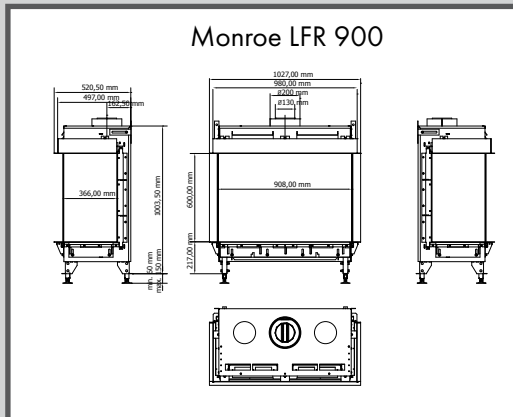
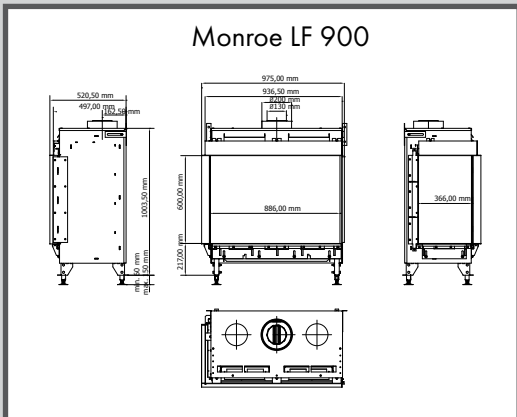
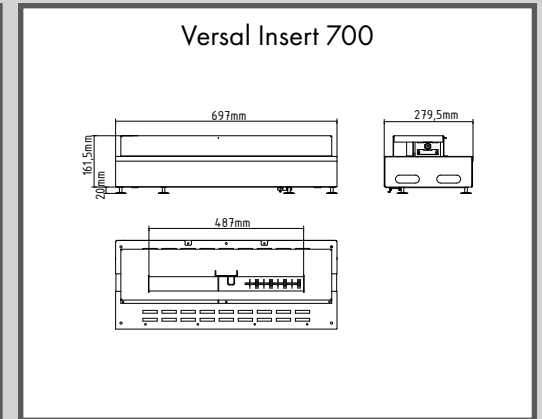
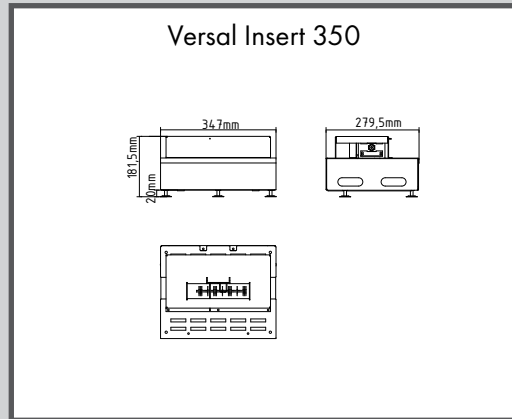
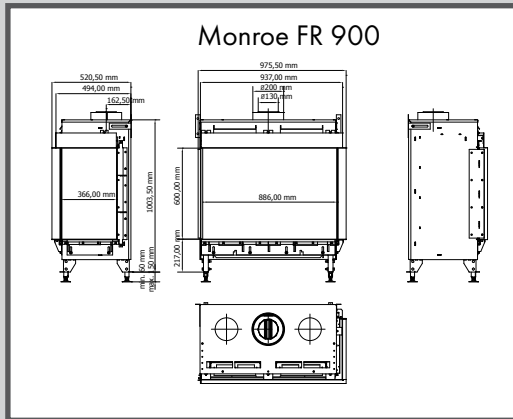
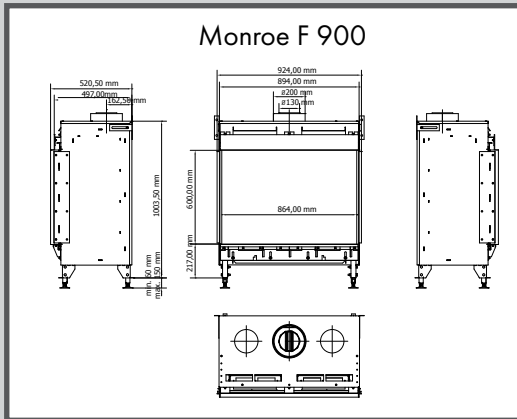

VERSAL FREESTANDING/CASSETTE

TECHNICAL DRAWINGS

VERSAL WOODBOX

TECHNICAL DRAWINGS

Versal 400

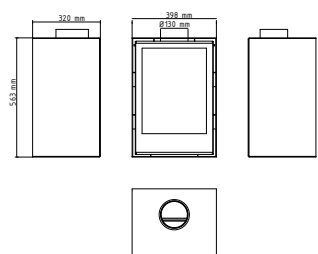

Versal 750

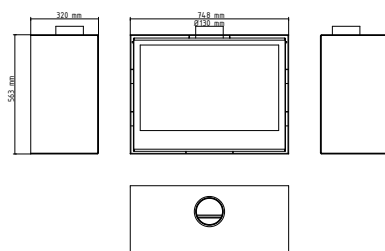

Versal 400 with Woodbox

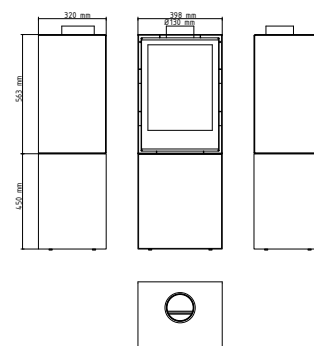

Versal 750 with Woodbox

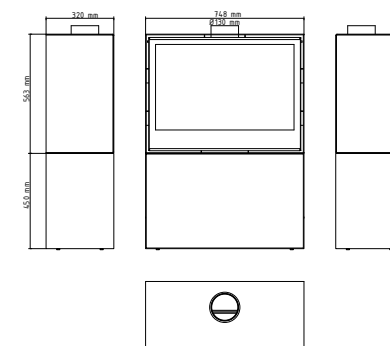

Versal 600

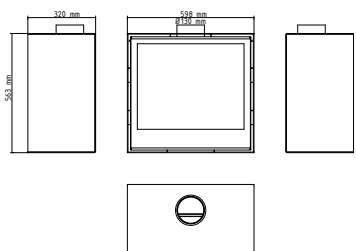

Versal 900

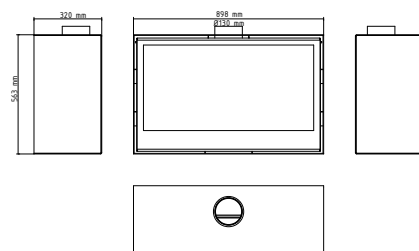

Versal 600 with Woodbox

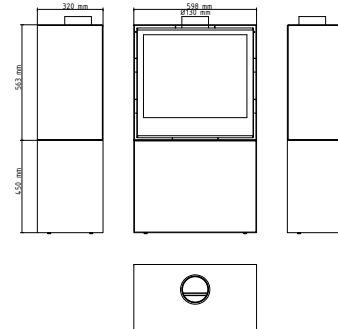

Versal 900 with Woodbox

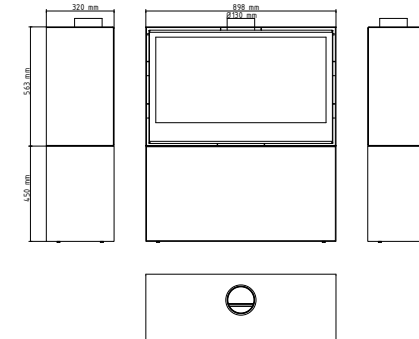

VERSAL GASBOX

TECHNICAL DRAWINGS

OUTDOOR

TECHNICAL DRAWINGS

Versal 400 with Gasbox

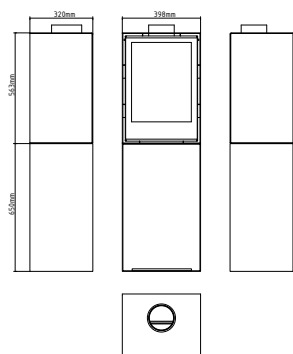

Versal 750 with Gasbox

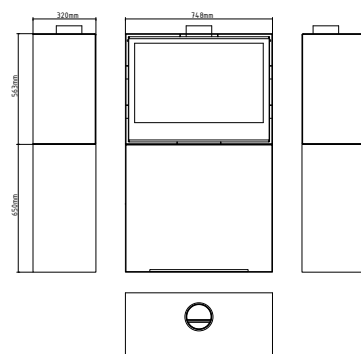

Galio Corten

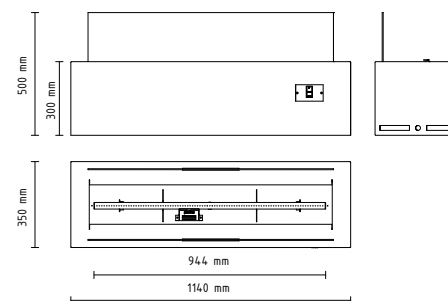

Galio Fire Pit Corten

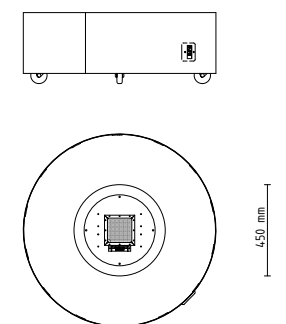

Versal 600 with Gasbox

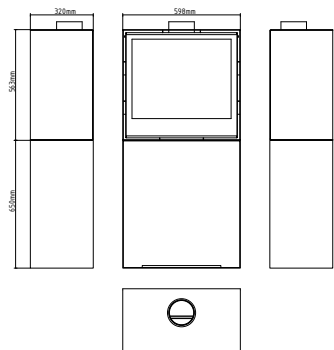

Versal 900 with Gasbox

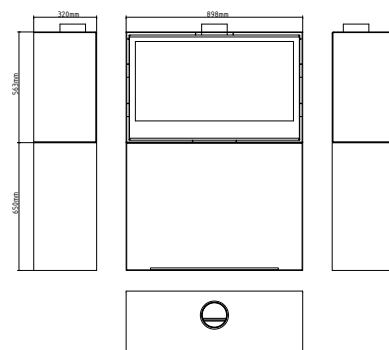

Galio Insert

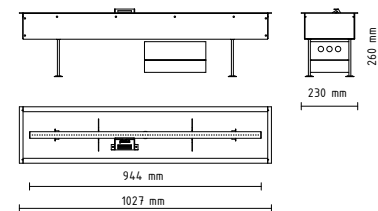

Galio Fire Pit Insert

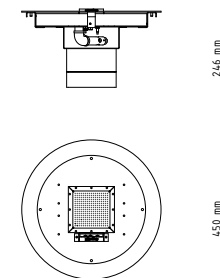

**DESIGNED
IN USA** 

planika
INTELLIGENT FIRE

PLANIKA USA LLC
1 Ackerman Avenue
Clifton, NJ 07011
T: (201) 933 7787
F: +1 201 933 7741
www.planikausa.com
info@planikausa.com

PLANIKA - Production Plant Poland
Bydgoska 38
86-061 Brzoza, Poland
T: +48 52 364 11 60
F: +48 52 364 11 70
www.planikafires.com
planika@planikafires.com